

ADJUSTABLE PIPE ROLLER STAND

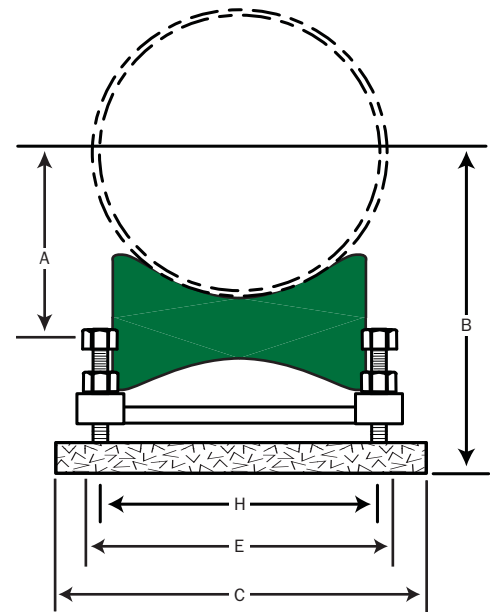
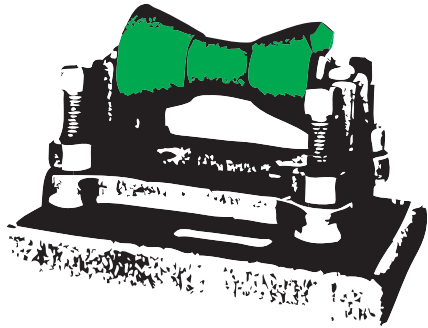

ADJUSTABLE PIPE ROLLER STAND INCLUDES:

- 1 CAST IRON OR STEEL BASE
- 1 CAST IRON OR STEEL BASE PLATE
- 4 ADJUSTABLE BOLTS & LOCKING NUTS
- 1 ROLL AXLE
- 1 CAST IRON ROLL (OMIT WHEN ORDERING NON-CONDUCTIVE ROLLER)

All Dimensions in inches

Pipe Size	A	B		C	D	E	F	G	H	I	Max. Load lbs.	Weight lbs. ea.	Axle
		Min	Max										
2	1 13/16	4 1/2	5 7/8	6 7/8	5 1/2	3 7/8	1	5/8	3 1/2	4	390	14.56	1/2
2 1/2	2 1/16	4 3/8	6	6 7/8	5 1/2	3 7/8	1	5/8	3 1/2	4	390	14.56	1/2
3	2 3/8	5	6 3/8	6 7/8	5 1/2	3 7/8	1	5/8	3 1/2	4	390	14.56	1/2
3 1/2	2 5/8	5 1/4	6 5/8	6 7/8	5 1/2	3 7/8	1	5/8	3 1/2	4	390	14.56	1/2
4	2 3/4	5 3/4	7 1/4	8 1/8	5 3/4	5 1/8	1	5/8	4 7/8	4 3/8	950	18.32	1/2
5	3 3/8	6 1/4	7 3/4	8 1/8	5 3/4	5 1/8	1	5/8	4 7/8	4 3/8	950	18.32	1/2
6	3 15/16	6 7/8	8 3/8	8 1/8	5 3/4	5 1/8	1	5/8	4 7/8	4 3/8	950	18.32	1/2
8	5 1/4	9 5/8	11 3/4	10 5/8	6 3/4	7 3/8	1 1/8	5/8	7 1/16	5 1/16	2100	32.38	3/4
10	6 3/8	10 3/4	12 7/8	10 5/8	6 3/4	7 3/8	1 1/8	3/4	7 1/16	5 1/16	2100	32.38	3/4
12	7 1/2	12 1/8	14 3/4	13 1/4	8 3/16	9 3/4	1 1/8	7/8	9 1/4	6 1/16	3075	50.63	7/8
14	8 1/2	13	15 5/8	13 1/4	8 3/16	9 3/4	1 1/8	7/8	9 1/4	6 1/16	3075	50.63	7/8
16	9 1/4	14 3/4	18 1/8	14 5/8	8 5/8	11 1/8	1 1/4	1	10 3/4	6 3/4	4980	76.75	1 1/8
18	10 3/8	16 1/8	19 1/2	14 5/8	8 5/8	11 1/8	1 1/4	1	10 3/4	6 3/4	4980	76.75	1 1/8
20	11 3/8	17	20 3/8	14 5/8	8 5/8	11 1/8	1 1/4	1	10 3/4	6 3/4	4980	76.75	1 1/8
24	13 3/8	19 1/8	22 1/2	15 3/4	8 3/4	12 1/4	1 3/8	1	11 5/8	7 5/8	6100	85.25	1 1/4
30	16 11/16	24	26 3/4	19 1/4	8 3/4	15 3/4	1 5/8	1 1/4	14 1/4	8 3/16	7500	165.5	1 3/4