

# ADJUSTABLE ROLLER HANGER

4B

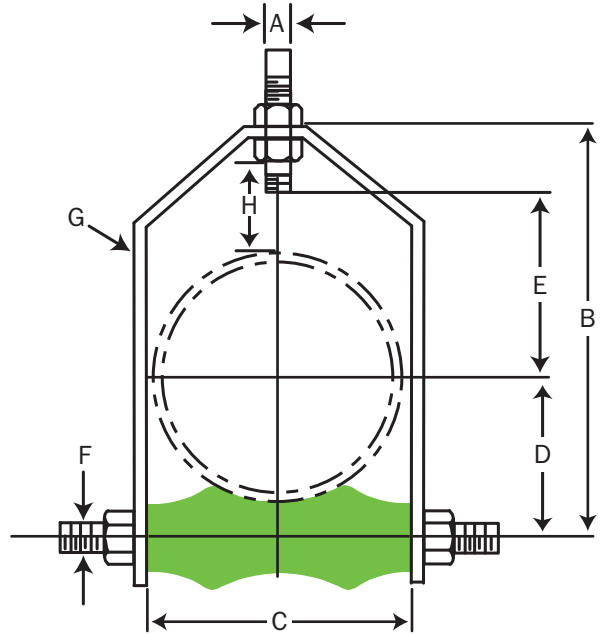
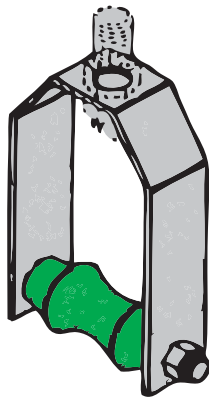

## ADJUSTABLE ROLL HANGER INCLUDES:

- 1 STEEL CLEVIS (YOKE)
- 1 ROLL AXLE & NUTS
- 1 CAST IRON ROLL (OMIT WHEN ORDERING NON-CONDUCTIVE ROLLER)

SPECIFICATIONS MAY VARY - All Dimensions in inches

Pipe Size	Rod Size A	B	C	D	Rod Take Out E	Axle F	Steel Size G	Adjust. H	Max. Load lbs.	Wt. lbs/ea.
2	1/2	4 1/4	2 3/4	1 5/8	2 5/8	1/2	3/16 x 1 1/4	1 7/16	225	1.6
3	1/2	6 3/8	3 7/8	2 1/4	3 1/8	1/2	3/16 x 1 1/4	1 5/8	310	2.2
4	5/8	7 9/16	4 15/16	2 13/16	3 5/8	1/2	1/4 x 1 1/2	1 5/8	475	3.2
5	5/8	9 1/8	6	3 7/16	4 1/2	5/8	3/8 x 1 3/4	1 15/16	685	6.3
6	3/4	10 5/16	7 1/8	4	5	3/4	3/8 x 2	1 7/8	780	9.3
8	7/8	12 11/16	9 1/4	5 1/8	6 1/8	7/8	3/8 x 2 1/2	2	780	14.5
10	7/8	15 1/16	11 1/4	6 3/8	7 1/4	7/8	3/8 x 2 1/2	2 1/16	965	18.8
12	7/8	17 7/16	13 1/4	7 7/16	8 3/8	1	1/2 x 2 1/2	2 1/4	1200	27.7
14	1	18 7/8	14 1/2	8 3/8	8 3/4	1 1/8	1/2 x 2 1/2	2	1200	39.1
16	1	20 13/16	16 1/2	9 3/8	9 11/16	1 1/4	1/2 x 2 1/2	1 15/16	1200	49.1
18	1	23 3/4	18 1/2	10 7/16	11 7/16	1 1/4	1/2 x 3	2 13/16	1400	57.8
20	1 1/4	26	20 1/2	11 5/8	12 1/4	1 1/4	5/8 x 3	2 1/2	1600	75.9