

DETAIL ITEM NO.6

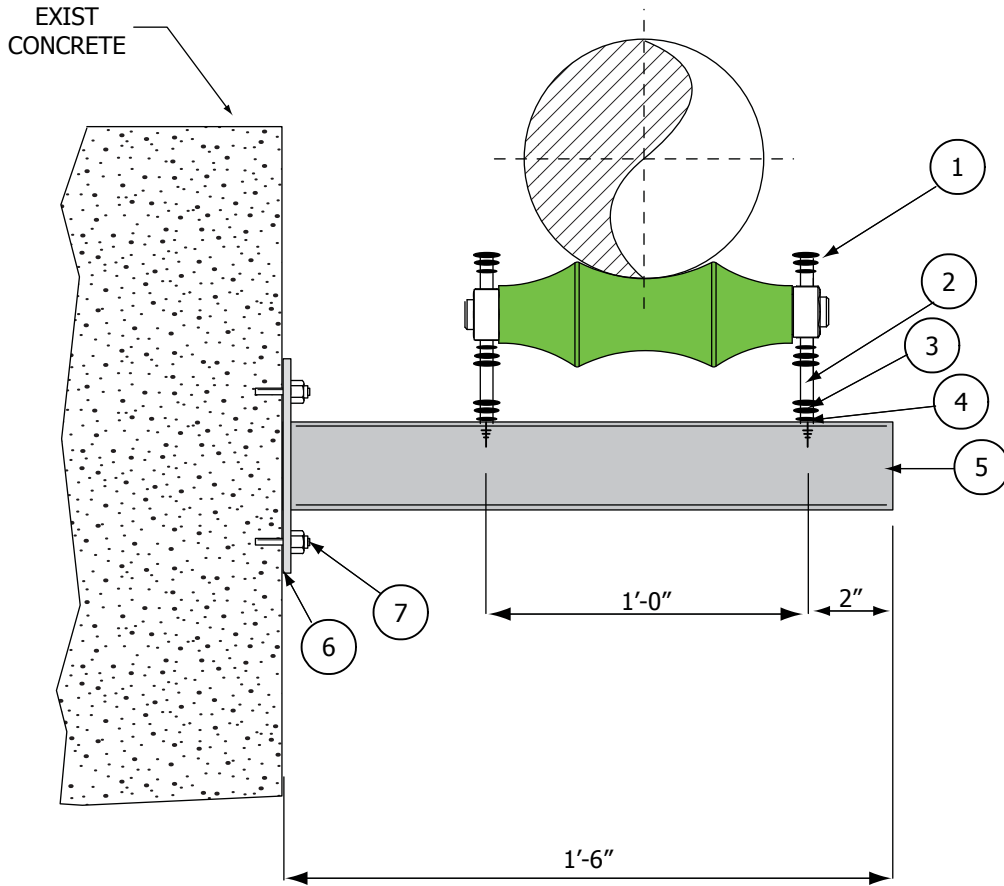

ELEVATION VIEW

NOT TO SCALE

ITEM	QTY	FIGURE NO.	FIN.	SIZE	LENGTH	MATERIAL DESCRIPTION
1	1	142	HDG	8"		ADJUSTABLE ROLL SUPPORT
2	2	94	SS	7/8"Ø	x1' -0"LG.	A.T. ROD (FIELD CUT TO SUIT)
3	16	165H	SS	7/8"		HEAVY HEX NUT
4	4	103	SS	7/8"		ROUND WASHER
5	1	CS	HDG	L4 x4	x3/8 x)-5 1/2"LG.	ANGLE W/(2) 15/16"x 1 1/2" LG. SLOTTED HOLE
6	1	CS	HDG	1/2"	x 8' x0'-8"LG.	PLATE W/(4) 3/4" Ø HOLE
7	4	1309	SS	5/8"Ø	x7"LG.	WEDGE ANCHOR (MIN. EMB=3 3/4")
8						
9						
10						
11						

NOTES

SS = STAINLESS STEEL TYPE 304
HDG = HOT DIP GALVANIZED

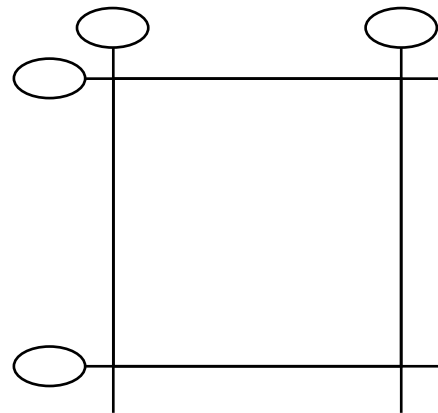

LOCATION PLAN

• PIPE ATTACH.

✕ STRUCT. ATTACH.

JOB NO. 3524

PIPE LOAD & MOVEMENT DATA

ANALYSIS NODE NO.	LATERAL	DOWN	AXIAL
○		-1400	
LOAD (lb)			
MOV'T (in)			

HYDRO. TEST LOAD: DN.

PIPE SPECIFICATIONS

PIPE SIZE	8"
PIPE SCH.	
TEMPERATURE	°F
INSULATION	
MATERIAL	CS

QUANTITY LINE NO. 8" G

REFERENCE DRAWINGS

- 1) _____ 3) _____
2) _____ 4) _____

PIPE SUPPORT DRAWING

LB&A, INC
LINN BROWN & ASSOCIATES
A UTILITY SERVICE COMPANY

WESTTOWN, PA

PIPING SYSTEM GAS

CODE NO.

DINO6_12_08

REV. 12/2008