

CUSTOMER APPROVAL
SPECIAL ITEMS ARE NON-RETURNABLE

BY:

DATE:

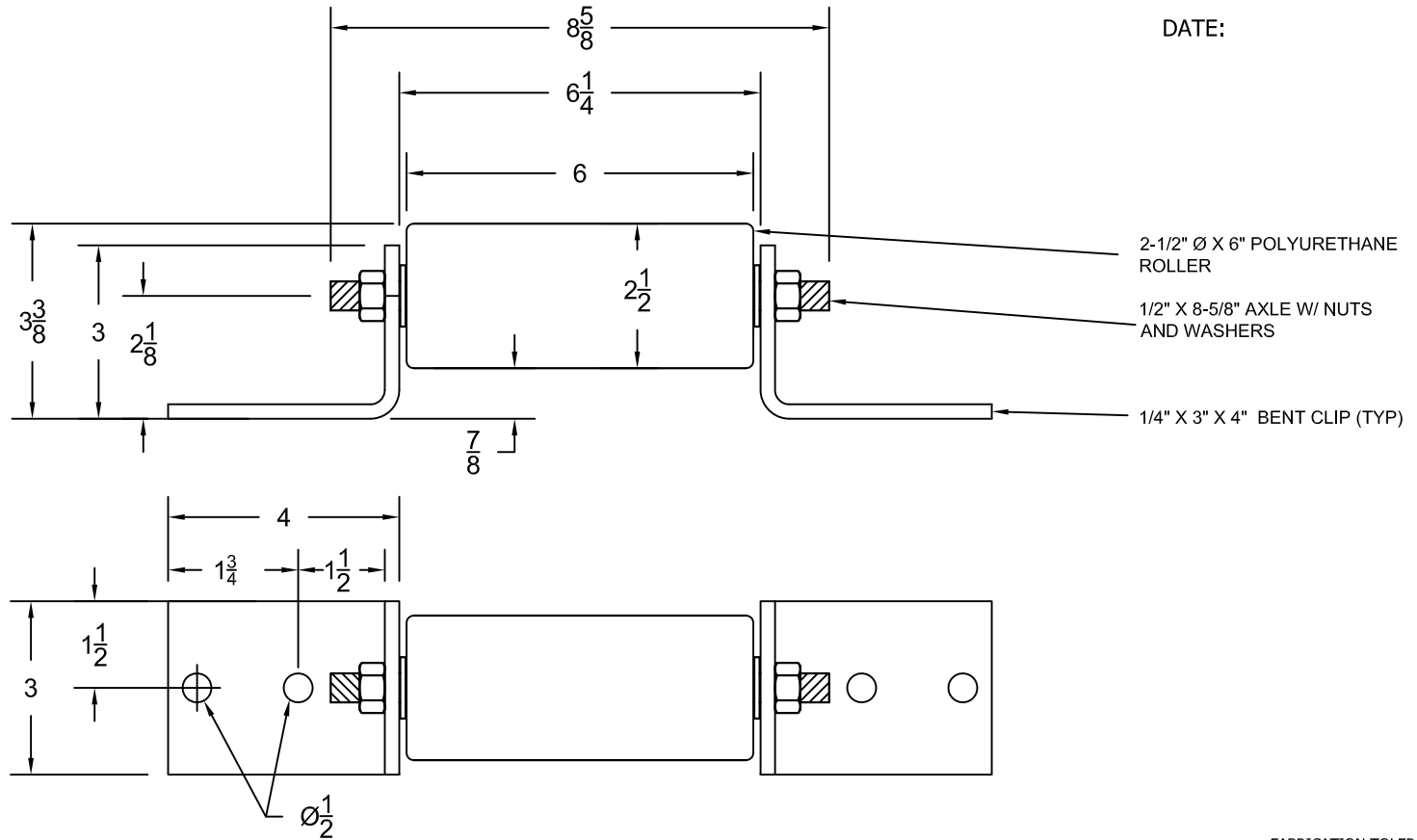

FABRICATION TOLERANCE
CUTTING: $\pm 1/8$ " $\pm 1^\circ$
FORMING: $\pm 4^\circ$
HOLD TOLERANCE
ASSEMBLY: $\pm 1/16$ " $\pm 1^\circ$

SPECIAL ITEMS ARE NON-RETURNABLE

The information herein reflects the materials, design, selection, and application as specified by the customer. Its purpose is for customer dimensional review and acceptance prior to fabrication. Linn Brown & Assoc. does not accept liability for engineering, load ratings, or other performance expectations.

NO.	REVISION	DATE

INFORMATION CONTAINED HEREIN IS THE CONFIDENTIAL PROPERTY OF LINN BROWN & ASSOCIATES AND MUST NOT BE DISCLOSED OR REPRODUCED WITHOUT PRIOR WRITTEN PERMISSION.

SPECIAL ITEM DESCRIPTION						FINISH	UNIT QTY.	LINN BROWN & ASSOC. 1085C Andrew Drive West Chester, PA 19380 610-696-9220 Phone 610-344-7519 Fax
ANGLE CLIP FOR 2-1/2" ROLLER						H D GALV	50	
CUSTOMER						JOB		
DRAWN BY	DATE	CHECKED BY	SCALE	P.O. NO.	DWG. NO.	REV.	TAG	
MS	4/6/16		5/16"=1"		040616B	0 0		