

COIL DESIGN HEAVY DUTY CONCRETE INSERT

18B-1

SAFE WORKING LOADS REFLECT A 3:1 SAFETY (ULTIMATE WORKING LOAD)
FOR CONCRETE COMPRESSIVE STRENGTH OF 3000 psi (20.7 MPa)

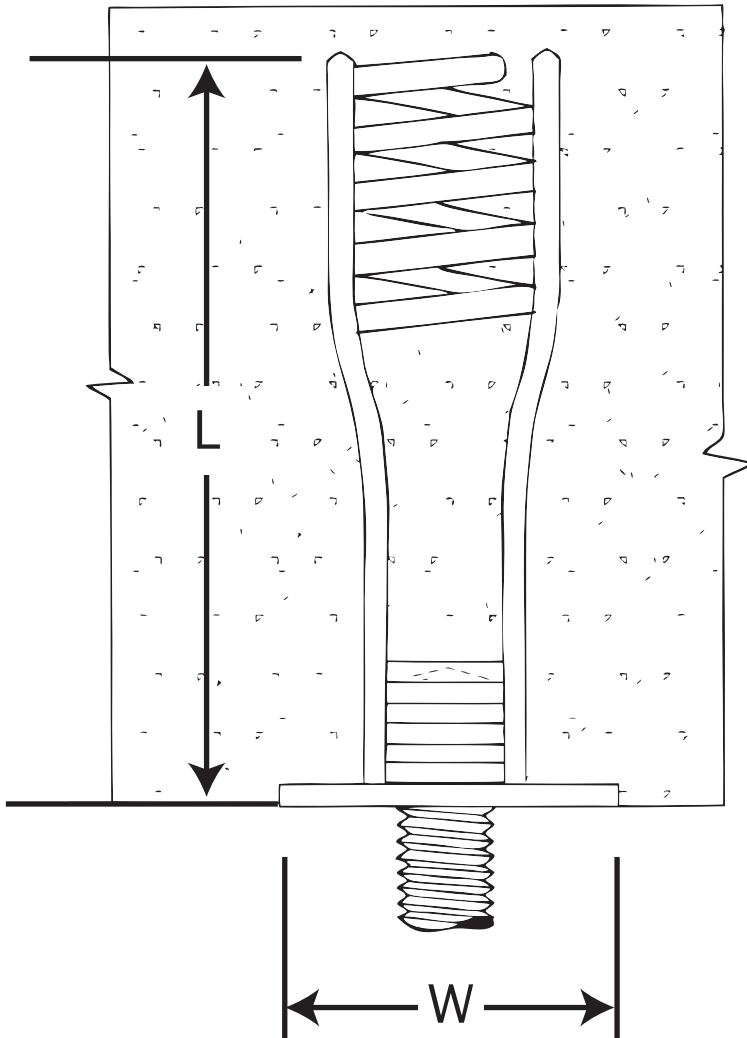

4 MOUNTING HOLES

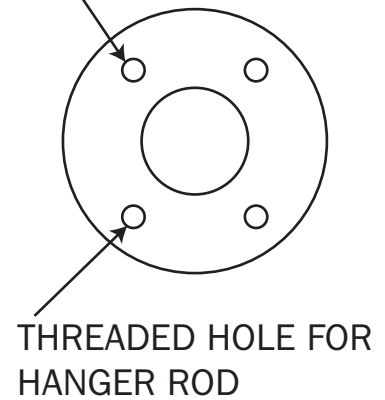

BOTTOM VIEW

HANGER ROD NOT INCLUDED

| ROD DIA. | WIDTH | LENGTH | SAFE LOAD Shear | WASHER THICKNESS | Minimum Concrete Thickness |
|----------|--------|--------|--------------------|---------------------|----------------------------------|
| 7/8" | 2 5/8" | 5 1/2" | 6000 lbs. | 3/16" | 6" |
| 1" | 2 5/8" | 5 1/2" | 8000 lbs. | 3/16" | 6" |
| 1 1/4" | 3 1/8" | 7 1/2" | 13,200 lbs. | 7/32" | 8" |
| 1 1/2" | 3 1/4" | 9 1/2" | 18,000 lbs. | 7/32" | 12" |