

## UTILITY SUPPORT DESIGN FOR ST. PAUL'S AVENUE

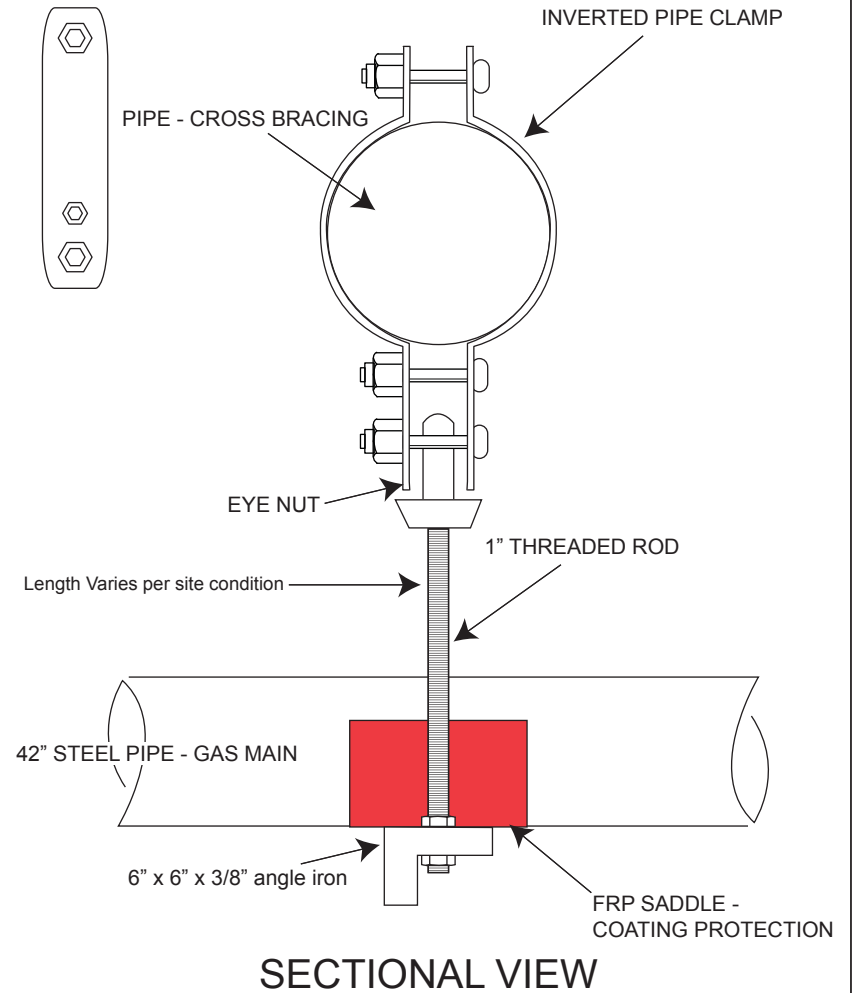

- Note:
1. Utility support design and unit provided by LB&A Inc.
  2. Each of these supports will be provided at a maximum spacing of 30" o.c.
  3. Indicative sketch only - actual dimensions per shop dwg./cut sheets