

APPROVED BY: _____
 DATE: _____

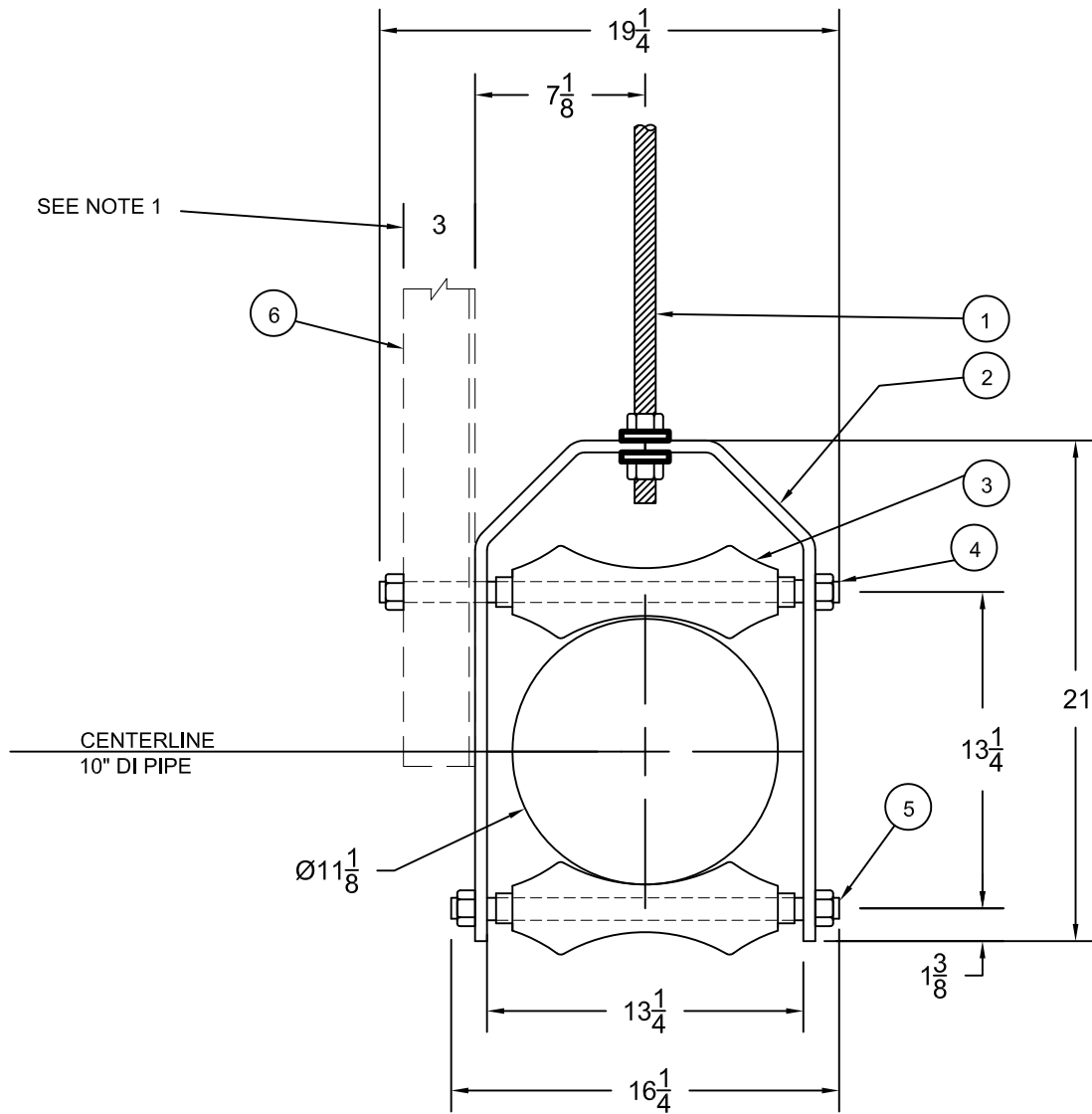

ITEM	DESCRIPTION
1	7/8" ALL THREAD ROD & NUTS
2	12" EXTENDED ROLLER HANGER YOKE 1/2" X 3" STEEL W/ DELRIN COLLARS
3	12" NON CONDUCTIVE ROLL (TYP)
4	7/8" X 19-1/4" AXLE 5" THREAD ONE END 1-1/2" THREAD OPPOSITE END
5	7/8" X 16-1/4" AXLE 1-1/2" THREAD EACH END
6	ANGLE BRACKET STEEL (BY OTHERS)

NOTE:
 1) ITEM #4 LENGTH BASED ON 3" ANGLE.
 FIELD TO CONFIRM THAT THIS IS
 CORRECT.

INFORMATION CONTAINED
 HEREIN IS THE CONFIDENTIAL
 PROPERTY OF LINN BROWN &
 ASSOCIATES AND MUST NOT BE
 DISCLOSED OR REPRODUCED
 WITHOUT PRIOR WRITTEN
 PERMISSION.

SPECIAL ITEMS ARE NON-RETURNABLE

SPECIAL ITEM DESCRIPTION 10" DI DOUBLE ROLLER ASSEMBLY				FINISH YOKE IS H D GALV THREADED COMPONENTS E.G.		UNIT QTY. 9		LINN BROWN & ASSOC. 1085C Andrew Drive West Chester, PA 19380 610-696-9220 Phone 610-344-7519 Fax	
CUSTOMER				JOB					
DRAWN BY MS	DATE 3/4/11	CHECKED BY	SCALE 1/8"=1"	P.O. NO.	DWG. NO. 030411B	REV. 0	0	TAG	